

Maximum Power Point Tracking (MPPT)

The built-in electronic unit gives the SQFlex system a number of advantages compared to conventional products. One of these advantages is the built-in microprocessor with MPPT (MPPT = **Maximum Power Point Tracking**).

Thanks to the MPPT-function, the pump duty point is continuously optimised according to the input power available. MPPT is only available for pumps connected to DC supply.

Wide voltage range

The wide voltage range enables the motor to operate at any voltage from 30-300 VDC or 90-240 VAC. This makes installation and sizing especially easy.

Reliability

The MSF 3 motor has been developed with a view to high reliability which is achieved through the following features:

- carbon/ceramic bearings
- excellent starting capabilities
- various protection facilities.

Installation

The following features ensure simple installation of the SQF pump:

- low weight ensuring user-friendly handling
- installation in 3", 4" or larger boreholes
- only an on/off switch is needed, which means that no extra motor starter / starter box is necessary
- SQF is available with cable and socket.

Note: Horizontal installation requires the water level electrode to be placed above the pump to ensure the dry-running protection.

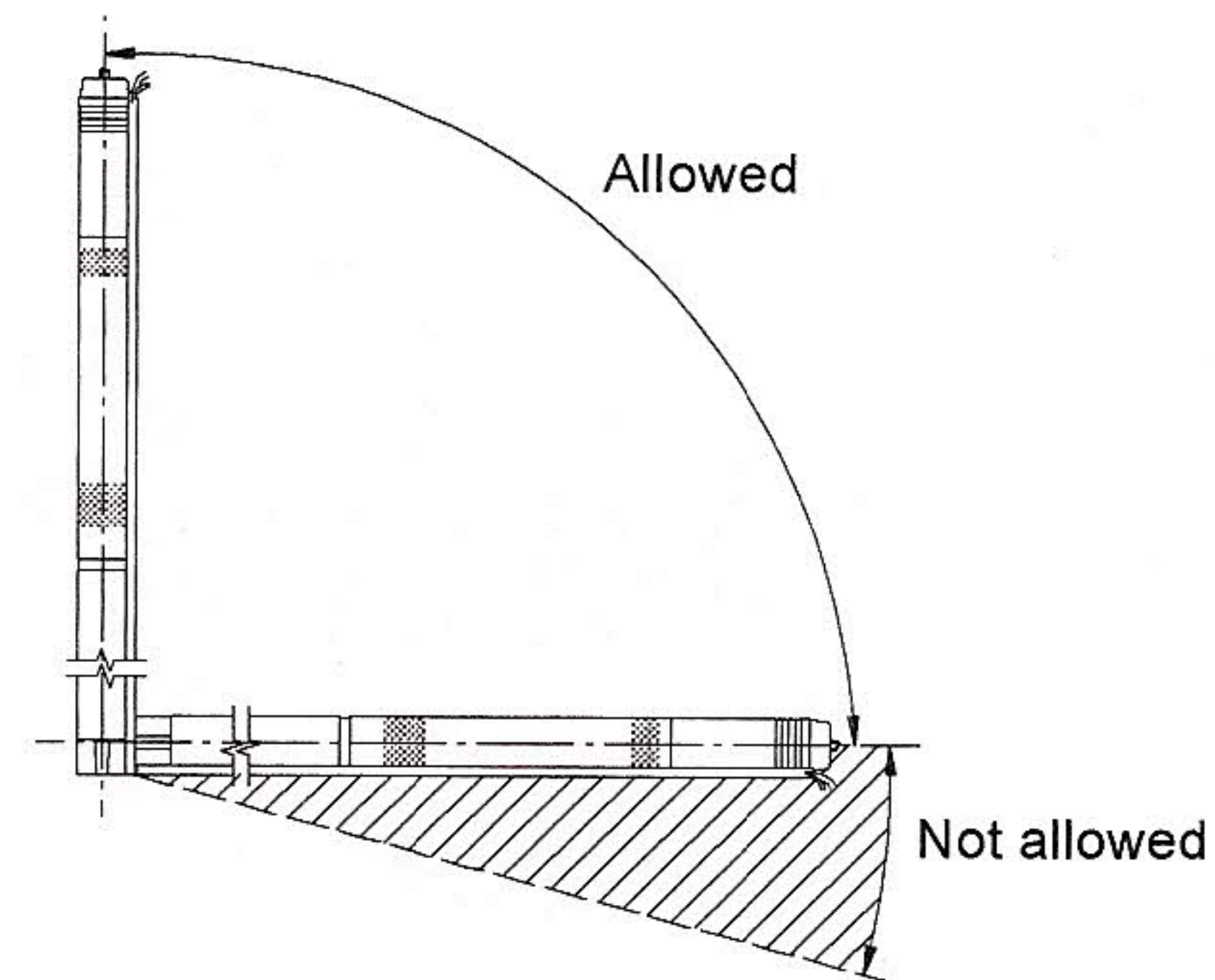

TM02 2246 3901

Fig. 4 Installation of SQF pumps

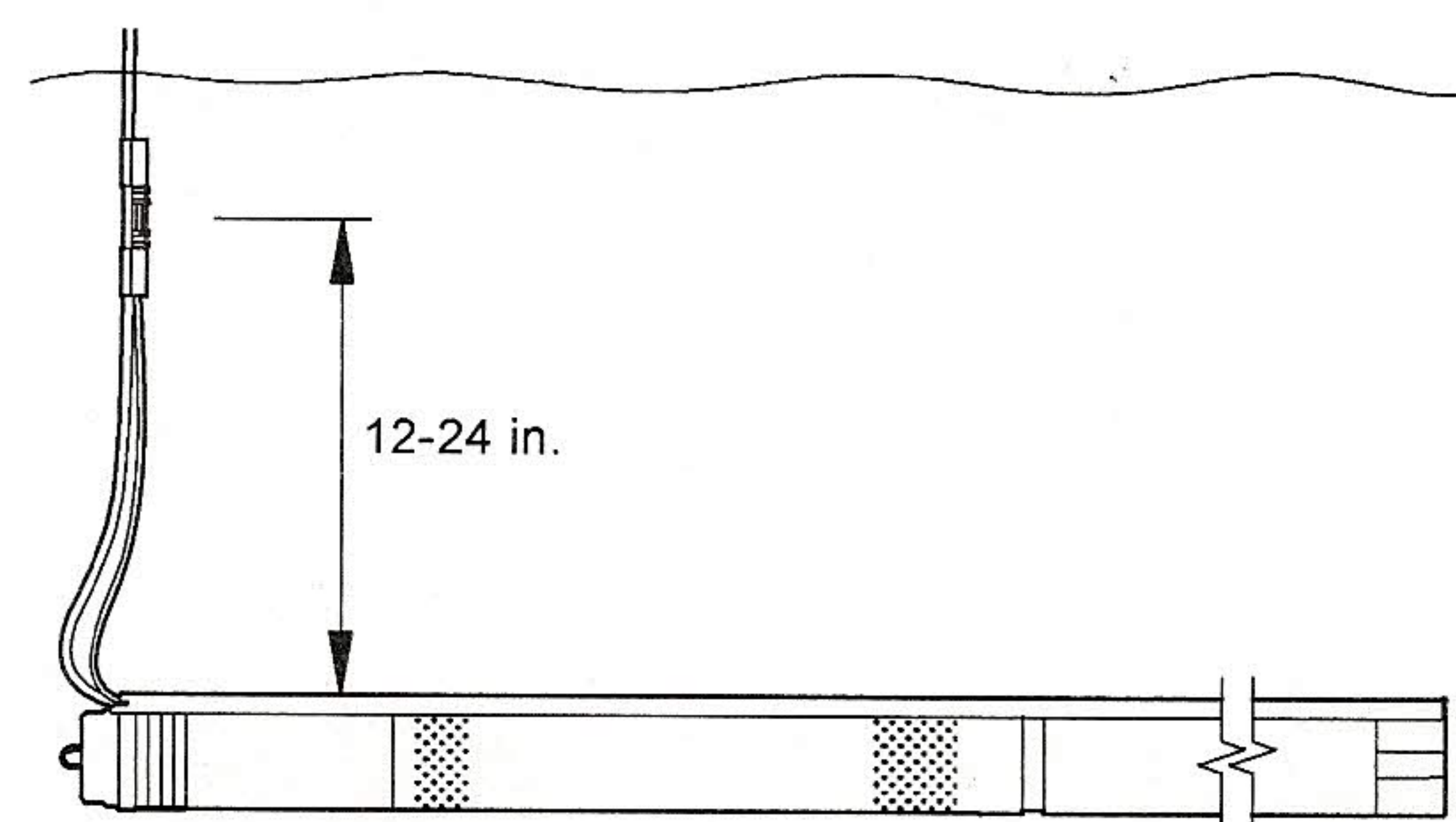

TM02 2435 3901

Fig. 5 Horizontal installation

Service

The modular pump and motor design facilitates installation and service. The cable and the end cover with socket are fitted to the pump with screws which enable replacement.

SQF submersible pump

The SQF pump is available as a complete unit only.

The SQF pump complete comprises

- motor
- 6 ft cable with water level electrode and socket
- cable guard.

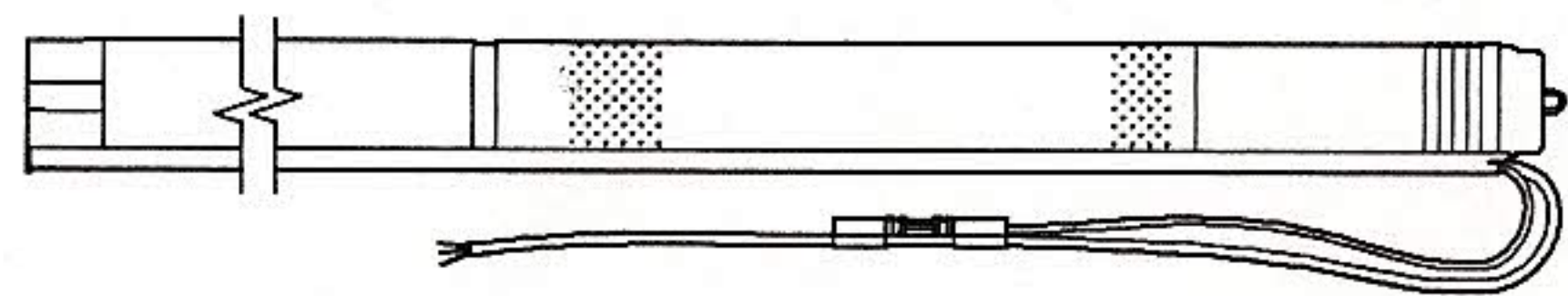

TM02 2217 3901

Fig. 15 SQF pump

The MSF motor is to be connected to the power supply as shown in fig. 16.

As the integrated electronic unit enables the motor to handle both DC and AC supply voltages, it makes no difference how the wires "+" and "-" or "N" and "L" are connected.

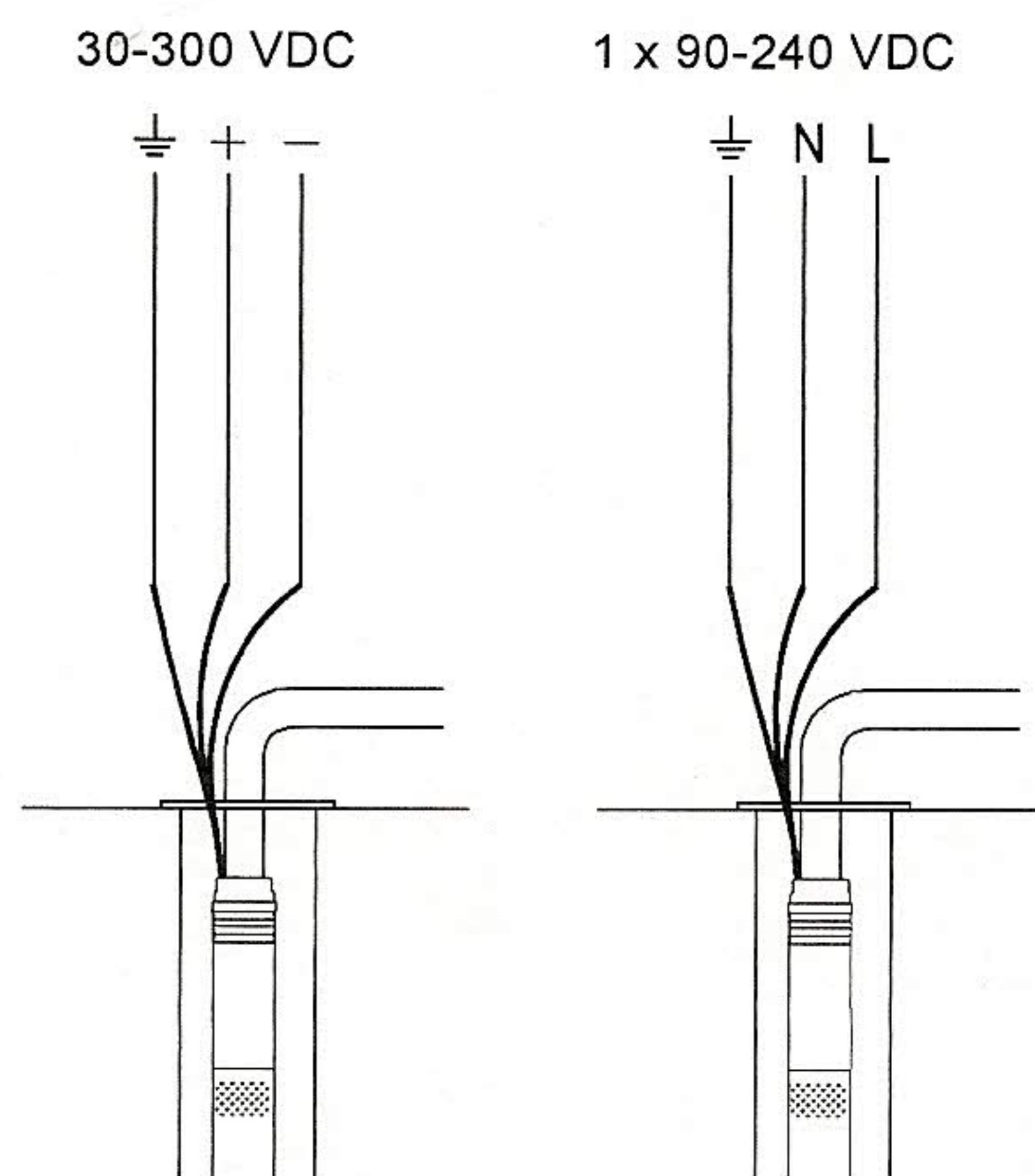

TM02 2437 3901

Fig. 16 Wiring diagram

CU 200 SQFlex control unit

The CU 200 is a combined status, control and communication unit especially developed for the SQFlex system. The CU 200 also enables connection of a level switch.

The CU 200 incorporates cable entries for

- power supply connection (pos. 6)
- pump connection (pos. 7)
- earth connection (pos. 8)
- level switch connection (pos. 9).

(The position numbers in brackets refer to fig. 17.)

Communication between the CU 200 and the pump takes place via the pump power supply cable. This is called mains borne signalling (or Power Line Communication), and this principle means that no extra cables between the CU 200 and the pump are required.

It is possible to start, stop and reset the pump with the on/off button (pos. 1). The CU 200 offers

- system monitoring
- alarm indication.

The following indications allow the operation of the pump to be monitored:

- water reservoir is full (level switch) (pos. 2)
- pump is running (pos. 3)
- input power (pos. 11).

The CU 200 offers the following alarm indications:

- Dry running (pos. 10)
- Service needed (pos. 5) in case of
 - no contact to pump
 - overvoltage
 - overtemperature
 - overload.

In addition, the CU 200 shows the symbols of the energy supply options (pos. 4).

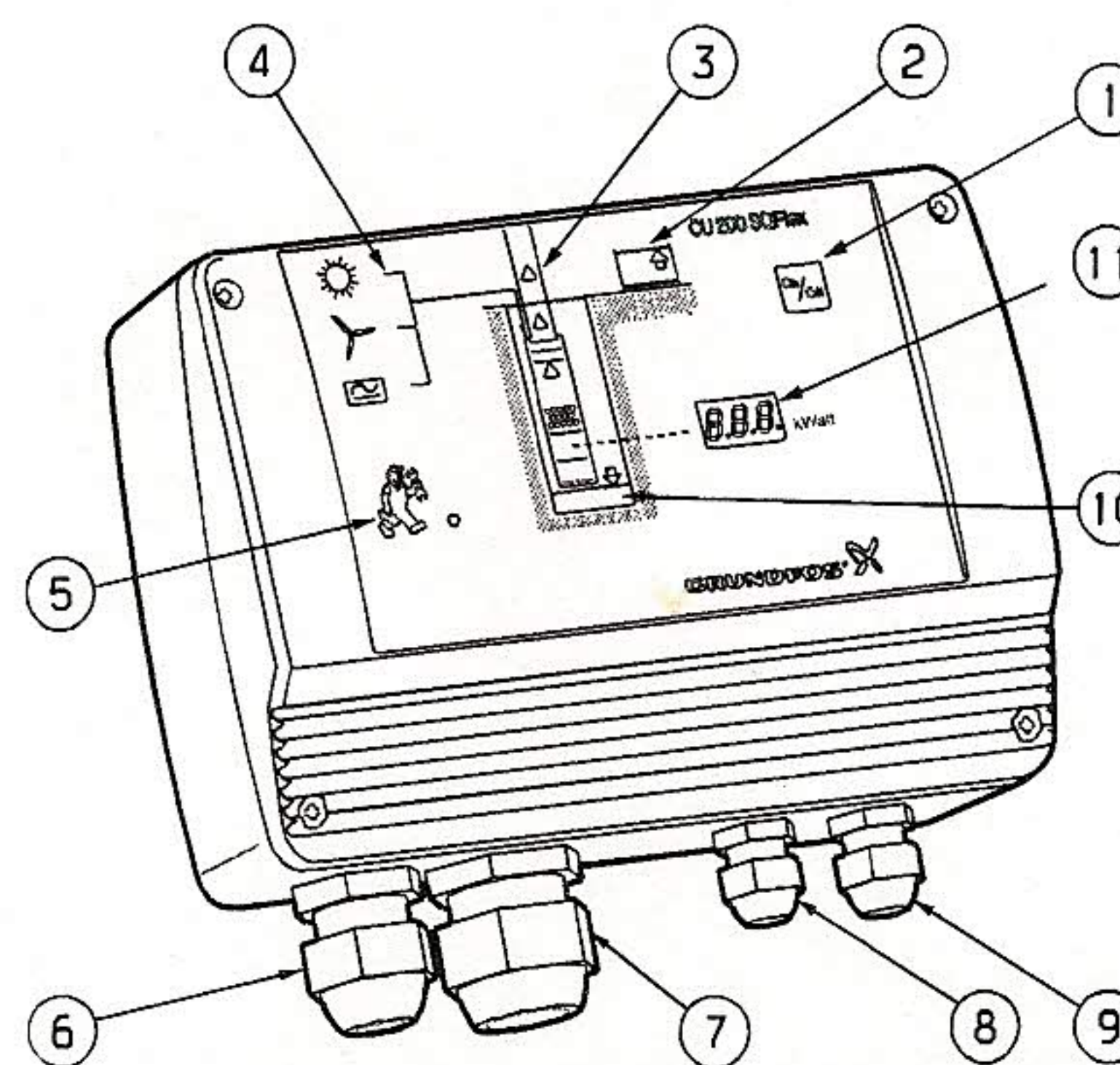
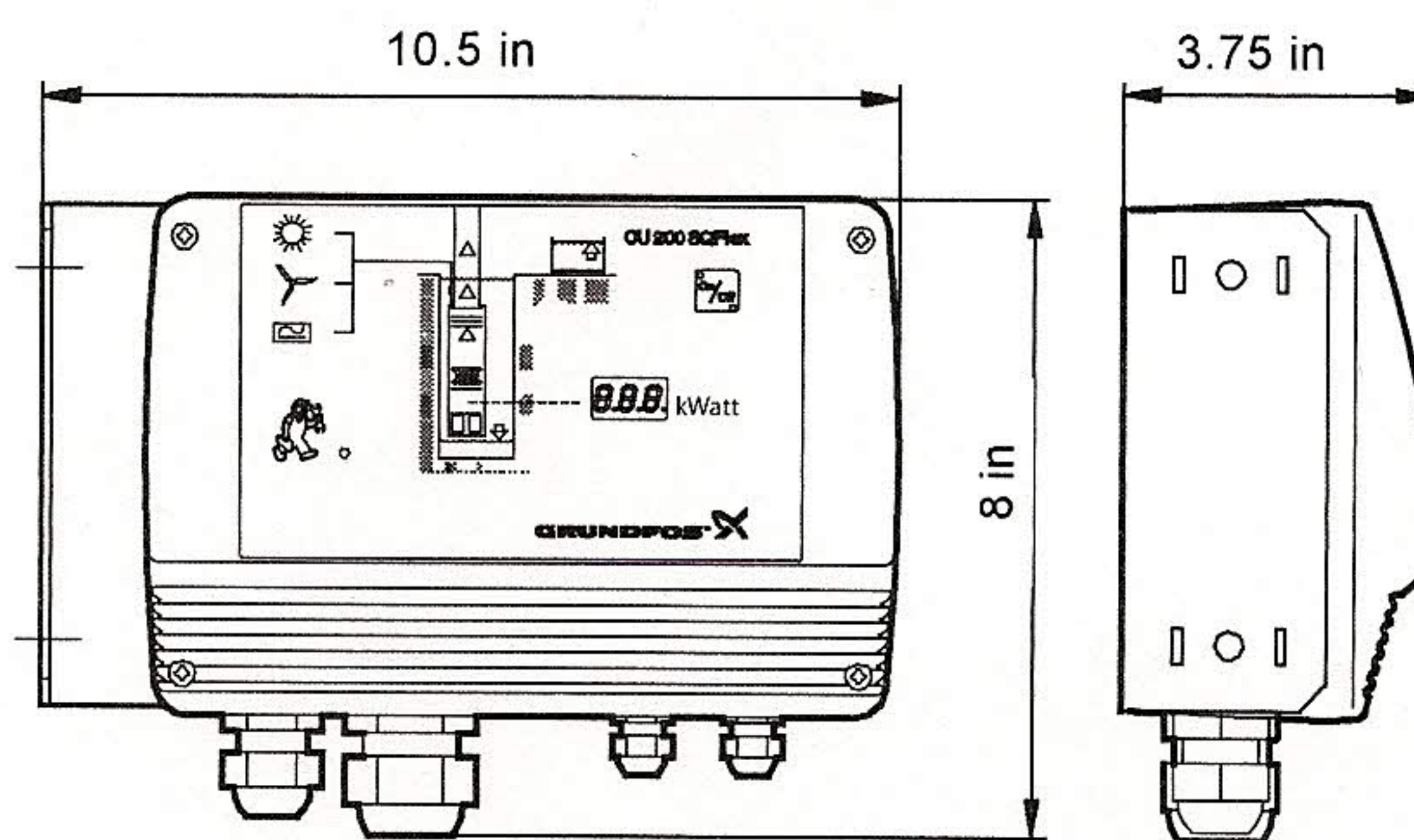

Fig. 17 CU 200 elements

TM02 2325 1206



TM02 2323 1206

Fig. 18 CU 200, dimensional sketch

Dimensions and weights

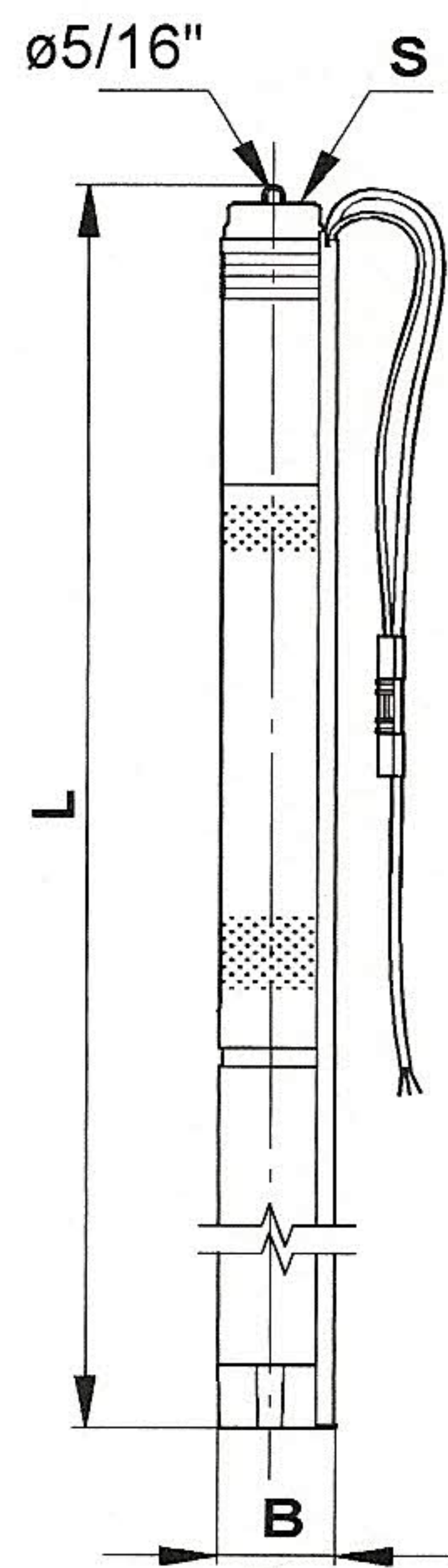

TM02 2209 3901

Pump type	Dimensions [in]			Net weight [lb]★	Gross weight [lb]★	Shipping volume [ft ³]★
	L	B	S			
3 SQF-2	47 *	2.9	1" NPT	17	21	0.85
3 SQF-3	49 *	2.9	1" NPT	17.5	21	0.85
6 SQF-2	48 *	2.9	1" NPT	17.5	21	0.85
11 SQF-2	49 *	2.9	1 1/4" NPT	18	22	0.85
16 SQF-10	38	3.9	1 1/4" NPT	21	24	1.00
25 SQF-3	32	3.9	1 1/2" NPT	18	21	1.00
25 SQF-6	35	3.9	1 1/2" NPT	19.5	23	1.00
40 SQF-3	36	3.9	2" NPT	21	24	1.00
40 SQF-5	40	3.9	2" NPT	23	26.5	1.00
60 SQF-3	39	3.9	2" NPT	24	27	1.00

★ Pump complete

Electrical data

30-300 VDC or 1 x 90-240 VAC, 50/60 Hz

Pump type	Motor type	Max. power input P ₁ [W]	Max. current [A]
3 SQF-2	MSF 3	900	8.4
3 SQF-3	MSF 3	900	8.4
6 SQF-2	MSF 3	900	8.4
11 SQF-2	MSF 3	900	8.4
16 SQF-10	MSF 3	1400	8.4
25 SQF-3	MSF 3	1400	8.4
25 SQF-6	MSF 3	1400	8.4
40 SQF-3	MSF 3	1400	8.4
40 SQF-5	MSF 3	1400	8.4
60 SQF-3	MSF 3	1400	8.4

